

DEUBLIN

1108 Series "Closed Seal" Rotating Unions for Continuous Coolant Service

- Single passage for coolant or MQL
- Closed seals for transfer line and similar applications
- Full-flow design has no obstructions to trap swarf or debris
- Bearing-supported with threaded rotor for easy installation
- Dual ABEC 7 (ISO class P4) angular contact ball bearings
- Labyrinth system and large vents to protect ball bearings
- Balanced mechanical seals made from silicon carbide for long life even under difficult operating conditions
- Aluminium housing, endcap anodised resists corrosion



Operating Data

Media	Water-based Coolant MQL (oil mist) up to 10 bar (145 psi)		
Filtration	ISO 4406 Class 17/15/12, max. 60 micron		
Max. Speed	20.000 min ⁻¹ 20,000 rpm		
Max. Pressure	see chart		
Max. Flow	82 l/min	21.6 gpm	Standard
	24,3 l/min	6.4 gpm	High Pressure
	2,7 l/min	0.7 gpm	Very High Pressure (VHP)
Max. Temperature	71 °C	160 °F	



DO NOT RUN DRY

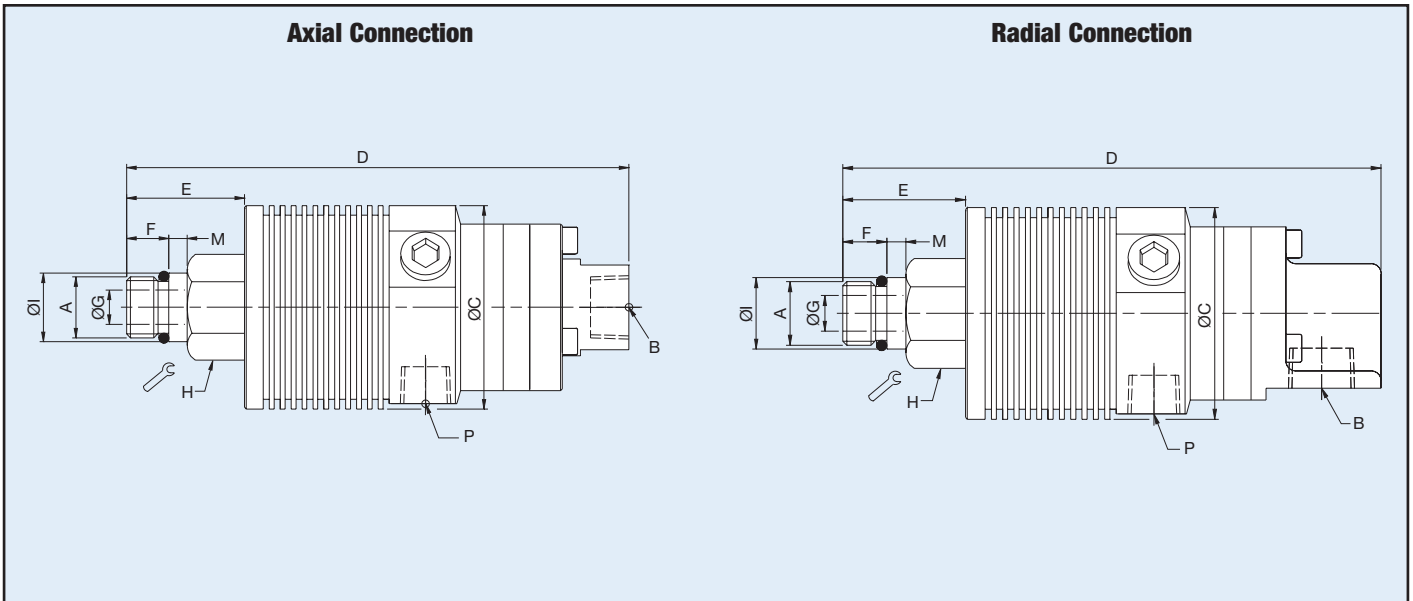
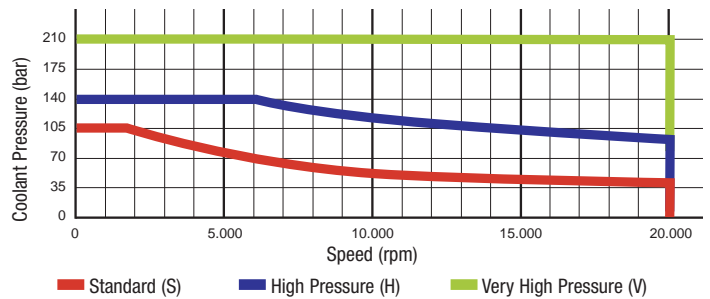

	Ordering Number	B Supply Connection	C Overall Diameter	D Overall Length	P Vent Size Ø (3 x 120°)	A Rotor Connection	E Rotor Length	F Thread Length	G Bore Diameter	H Across Flats	I Pilot Diameter	M Pilot Length
S	1108-002-153	3/8 NPT Axial	44	132	9	M16 x 1.5 LH	31	11	9	24	17.993 / 17.988	5
	1108-011-153	G 3/8 Radial	44	135	9	M16 x 1.5 LH	31	11	9	24	17.993 / 17.988	5
H	1108-034-212	G 1/4 Axial	53	129	G 1/4	M16 x 1.5 LH	31	11	9	24	17.993 / 17.988	5
	1108-058-212	G 1/4 Radial	53	135	G 1/4	M16 x 1.5 LH	31	11	9	24	17.993 / 17.988	5
V	1108-093-559	1/4 NPT Axial	44	132	9	M16 x 1.5 LH	31	11	9	24	17.993 / 17.988	5

【信德迈科技(北京)有限公司是美国Deublin杜博林旋转接头正式授权十年北方地区最大代理商】

产品选型资料及更详细产品介绍请点击：<http://www.cnmec.net>

DEUBLIN

1108 Series „Closed Seal” Bore-Mounted Rotating Unions for Coolant Service

- Single passage for coolant or MQL
- Closed seals
- Accepts up to 19 mm of draw bar movement
- Full-flow design has no obstructions to trap swarf or debris
- Labyrinth system and large vents to protect ball bearing
- Dry run cycles possible depending on model
- Balanced mechanical seals made from silicon carbide for long life even under difficult operating conditions
- Stainless steel housing and rotor
- Anodised aluminum end cap



Operating Data

Media	Water-based Coolant MQL (oil mist) up to 10 bar (145 psi)	
Filtration	ISO 4406 Class 17/15/12, max. 60 micron	
Max. Speed	see graph/table	
Max. Pressure	150 bar	2,176 psi
Max. Flow	24,3 l/min	6.4 gpm
Max. Temperature	71 °C	160 °F

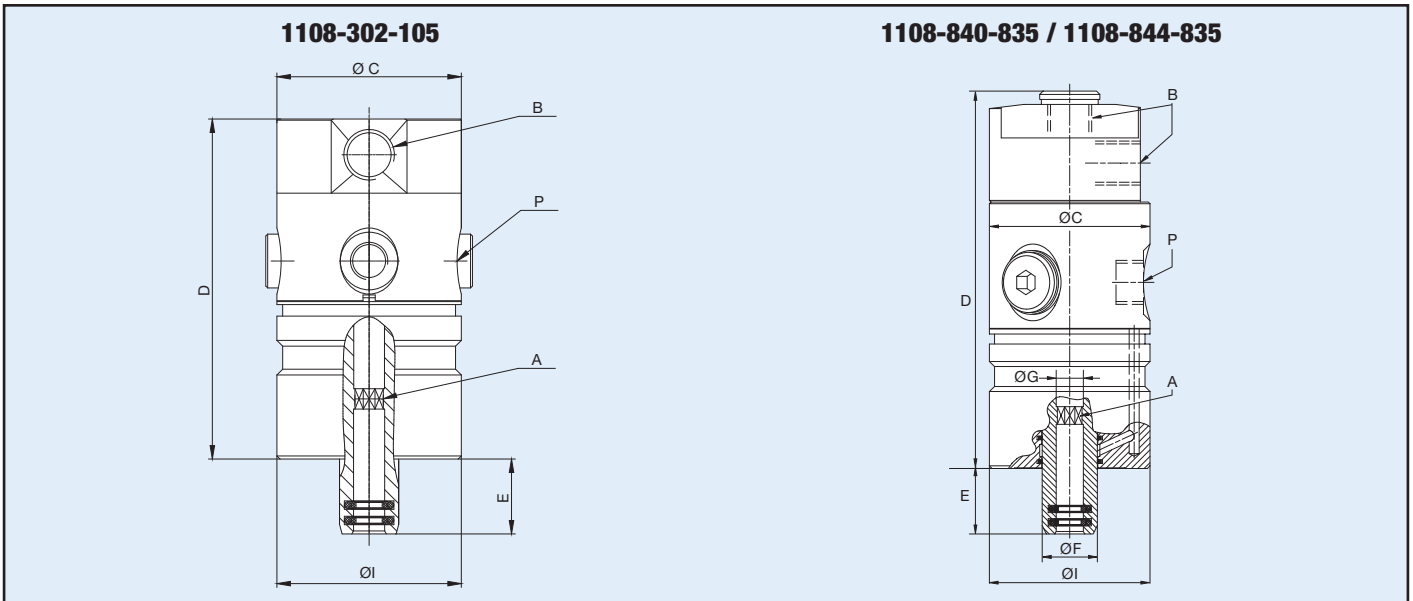
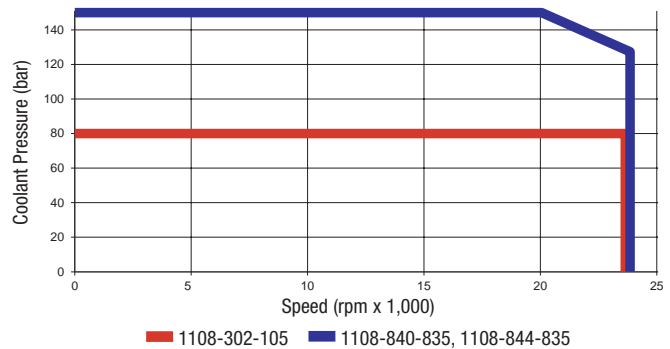

Ordering Number	B Supply Connection	C Overall Diameter	D Housing Length	P Vent Size Ø (3 x 120°)	A Rotor Connection	E Rotor Length	F Rotor Overall Diameter	G Bore Diameter	I Pilot Diameter	Maximum Speed (rpm)	Max. Pressure (bar)
1108-302-105	G ¼ Radial	48	88.5	G ¼ (4x90°)	Octagon 7.4 D10	19.5	15.4	8.1 F9	48 h7	24,000	80
1108-840-835	G ¼ Axial & Radial	48	112	G ¼ (3x120°)	Octagon 7.4 D10	19.5	15.9	8.1 F9	48 g6	24,000	150
1108-844-835	G ¼ Axial & Radial	48	112	4 mm (12x30°)	Octagon 7.4 D10	19.5	15.9	8.1 F9	44 g6	24,000	150

This series includes additional models.
Contact DEUBLIN at ☎ +49 (0) 6131-4998-0 or info@deublin.de