



# DEUBLIN

## Rotating Union 14000 Series for Air and Hydraulic Oil Service, DN 10 - 50

- monoflow design
- self-supported rotating union or in-the-shaft mounted
- balanced mechanical seal  
Carbon Graphite/Ceramic - for air service;  
Tungsten Carbide/Ceramic - for hydraulic service
- axial or radial housing connection by means of elbow
- lubrication storage within the seal cavity for air service
- heavy-duty design
- steel housing
- stainless steel rotor
- full-media flow

### Operating Data

Max. Air Pressure	150 PSI	10 bar
Max. Vacuum	2" Hg	7 kPa
Max. Hydraulic Pressure* (DN 10-20)	870 PSI	60 bar
(DN 25-40)	580 PSI	40 bar
Max. Speed* (DN 10-40)	1,500 RPM	1.500 min <sup>-1</sup>
(DN 50)	750 RPM	750 min <sup>-1</sup>
Max. Temperature	120 °C	> 120 °C consult DEUBLIN

Recommended filtration of Hydraulic Oil: 5 µm  
\* Operation at max. pressure combined with max. speed is not permissible

For further information please contact **DEUBLIN** or your local representative.

### Axial Version

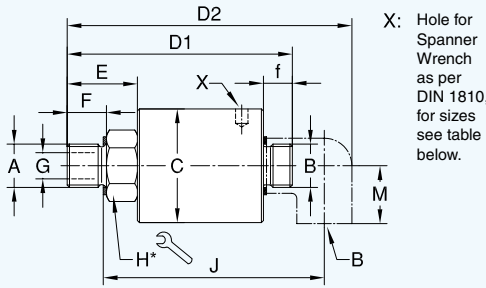

### In-the-Shaft Mounted Version

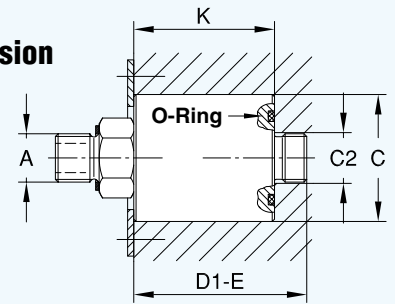

**How to Order:** Type a: 14037-03-094, straight-through version  
Type b: 14037-03-094-118, with elbow

Type c: 14037-03-094-120, in-the-shaft mounted version  
Type d: 14037-03-094-121, with elbow and O-ring.

\* DN 10 - 20 = hexagon  
DN 25 - 50 = two wrench flats

DN	B	Ordering No.		Type			A	C <sub>R8</sub> <sup>Eg</sup>	C <sub>2</sub>	D <sub>1</sub>	D <sub>2</sub>	E	F	f	G	H	J	K	M	X	kg	
		Type a for Air CG/C with lubricator	Type a for Hydr. Oil TC/C	b	c	d																Rotor Connections
10	G 3/8	14037-03-094	14037-04-192	-118	-120	-121	G 3/8	RH	42	18	93	119	26	16	12	9,5	22	93	54,5	25	40/42	0,5
		14037-03-095	14037-04-193				G 3/8	LH	42	18	93	119	26	16	12	9,5	22	93	54,5	25	40/42	0,5
15	G 1/2	14050-03-151	14050-04-154	-118	-120	-121	G 1/2	RH	55	22	109	138	34	19	14	12,7	30	107	60,5	28	52/55	1
		14050-03-152	14050-04-160				G 1/2	LH	55	22	109	138	34	19	14	12,7	30	107	60,5	28	52/55	1
20	G 3/4	14075-03-284	14075-04-447	-118	-120	-121	G 3/4	RH	63	28	122	158	34	19	16	19	36	124	71,5	33	58/62	1,7
		14075-03-285	14075-04-448				G 3/4	LH	63	28	122	158	34	19	16	19	36	124	71,5	33	58/62	1,7
	G 3/4	14075-03-458	14075-04-936	-118	-120	-121	M27 x 1,5	RH	63	28	123	159	35	15	16	19	36	121	71,5	33	58/62	1,7
		14075-03-459	14075-04-937				M27 x 1,5	LH	63	28	123	159	35	15	16	19	36	121	71,5	33	58/62	1,7
	G 3/4	14075-03-014	14075-04-451	-118	-120	-121	M35 x 1,5	RH	63	28	126	161	38	15	16	19	41	131	71,5	33	58/62	1,7
		14075-03-015	14075-04-452				M35 x 1,5	LH	63	28	126	161	38	15	16	19	41	131	71,5	33	58/62	1,7
25	G 1	14100-03-222	14100-04-378	-118	-120	-121	G 1	RH	80	35	138	181	41	22	18	25	36	140	78,5	38	80/90	2,4
		14100-03-223	14100-04-379				G 1	LH	80	35	138	181	41	22	18	25	36	140	78,5	38	80/90	2,4
	G 1	14100-03-235	14100-04-381	-118	-120	-121	M35 x 1,5	RH	80	35	132	175	35	15	18	25	36	141	78,5	38	80/90	2,4
		14100-03-236	14100-04-382				M35 x 1,5	LH	80	35	132	175	35	15	18	25	36	141	78,5	38	80/90	2,4
32	G 1 1/4	14125-03-054	14125-04-128	-118	-120	-121	G 1 1/4	RH	90	43	153	205	55	28	20	31,8	46	155	77,5	45	80/90	3,3
		14125-03-055	14125-04-129				G 1 1/4	LH	90	43	153	205	55	28	20	31,8	46	155	77,5	45	80/90	3,3
40	G 1 1/2	14150-03-198	14150-04-288	-118	-120	-121	G 1 1/2	RH	90	49	184	243	72	29	22	38	55	187	89,5	50	80/90	4
		14150-03-199	14150-04-289				G 1 1/2	LH	90	49	184	243	72	29	22	38	55	187	89,5	50	80/90	4
	G 1 1/2	14150-03-200	14150-04-418	-118	-120	-121	M50 x 1,5	RH	90	49	177	236	65	23	22	38	55	187	89,5	50	80/90	4
		14150-03-201	14150-04-419				M50 x 1,5	LH	90	49	177	236	65	23	22	38	55	187	89,5	50	80/90	4
50	G 2	14200-03-124	---	-118	-120	-121	G 2	RH	110	61	205	275	65	29	25	50	60	213	114,5	58	110/115	6
		14200-03-125	---				G 2	LH	110	61	205	275	65	29	25	50	60	213	114,5	58	110/115	6