

DEUBLIN[®]
Engineered for Performance



Rotating Unions
STEEL INDUSTRY

DEUBLIN KEEPS THE WORLD ROTATING



Since 1945, Deublin has grown from a small garage shop to the world's largest manufacturer of rotating unions. Today, Deublin's international headquarters is located in Waukegan, Illinois, with manufacturing facilities, sales offices and warehouses located in 17 countries on four continents.

Our worldwide distribution network allows end users all over the world to specify Deublin unions when purchasing equipment made in another country. We're manufacturers ourselves, so we understand the importance of fast response time to keep your manufacturing process rolling. Wherever you're located, Deublin has a stocking distributor nearby to meet your requirements—quickly.



UNIQUE REQUIREMENTS DEMAND CUSTOM UNIONS

Rotating unions must accommodate a broad range of materials, viscosities, temperatures, pressures and speeds. That's why the Deublin product line offers over 500 standard unions, over 3,000 separate models.

Even this extensive line cannot meet all the specialized needs required by our customers. That's why we manufacture an ever-growing line of custom unions to meet individual manufacturers' particular requirements. In many instances, we can adapt or convert an existing union and offer a cost-effective solution to meet your exact specifications.



ROTATING UNIONS FOR STEEL INDUSTRY

Deublin has been the world's largest manufacturer of rotating unions for the general industry for over 65 years and specialty unions for the continuous casting industry for over 45 years. Deublin has worked closely with designers and users of continuous casting equipment and as a result, has developed a number of solutions to the unique requirements of continuous casting applications.

Rotating unions are used to transmit cooling water in and out of the rolls of caster segments and, therefore, are critical components of every continuous casting machine (CCM). Rotating union performance can often make the difference between a productive operation or a casting operation with frequent downtime, maintenance, and repair.

A rotating union is composed of 3 parts — a housing that turns with the caster roll, a stationary hollow sleeve that connects the water supply and return and a balanced mechanical seal that acts as a leak-proof rotating connection. The critical component is the mechanical seal.

Deublin unions have **balanced mechanical seals** with seal faces that are micro lapped to an optical flatness of better than 2 light bands. The seal faces are made of silicon carbide to provide the ultimate wear resistance in harsh and abrasive environments. While Deublin's standard unions have a one-year warranty — the 2400 Series, due to its robust design and advanced technology, is offered with a **two-year warranty**.

In today's very competitive environment, Deublin unions can help you reduce maintenance costs and enjoy the profitability of longer, high tonnage campaigns.

Deublin also offers **rebuilding and exchange programs** that can be designed to complement your section-rebuilding schedule. This assures you of always having a dependable quality union at a fraction of the cost of a new union. Deublin 55 Series unions for Tunnel Furnace applications are featured in our Standard Union Catalog.

Quality Credentials

Deublin pursues its design and manufacturing missions with a passionate belief in the premise that quality is designed-in, not inspected in — a philosophy that is at the heart of its independently registered ISO 9001 compliant Quality Management System. This recognition offers assurance that our customers' end-use environment, performance requirements and reliability expectations are always captured and expressed in our product designs, as well as at every stage of development and manufacture. It means that "lessons learned" in hundreds of product applications are projected forward into continual improvement of both our product and processes. Our ISO 9001 recognition is therefore simply more evidence of Deublin's unmatched reputation for customer satisfaction and product quality.

In addition, Deublin is certified as an Authorized Economic Operator (AEO), which provides assurance that Deublin's supply chain is approved as both secure and customs-reliable. This recognition fast-tracks the flow of goods and materials worldwide — a customer service advantage for all of our supply chain partners.

MANUFACTURING PROCESS

Foundry/Casting



Hot Rolled



Cold Rolled



Finishing

STEEL CONTINUOUS CASTING MACHINE

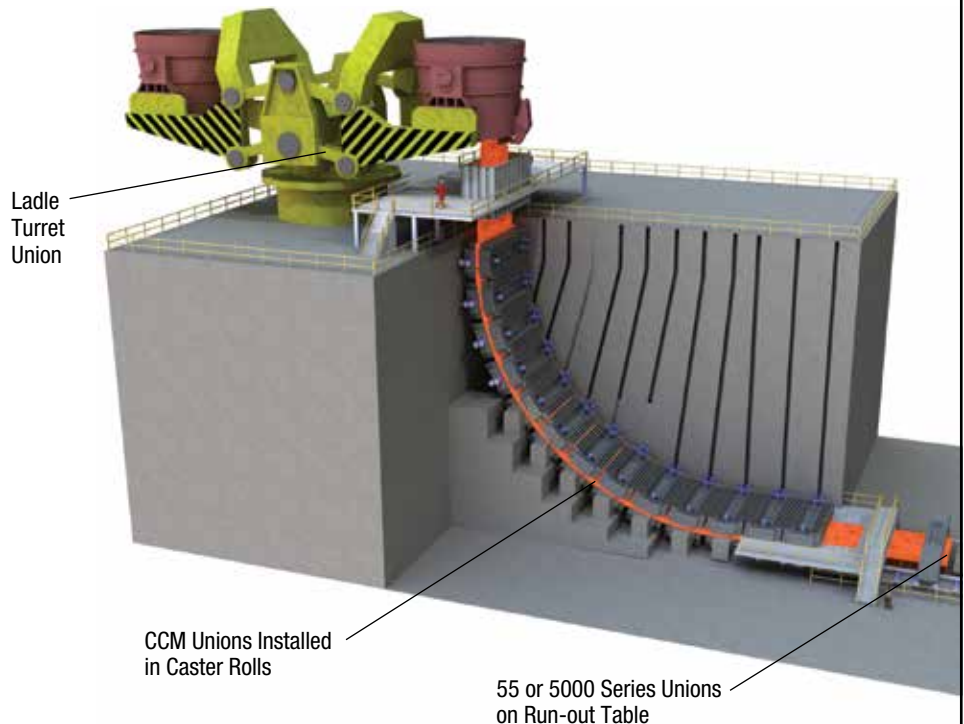

ROTATING UNIONS FOR CONTINUOUS CASTING

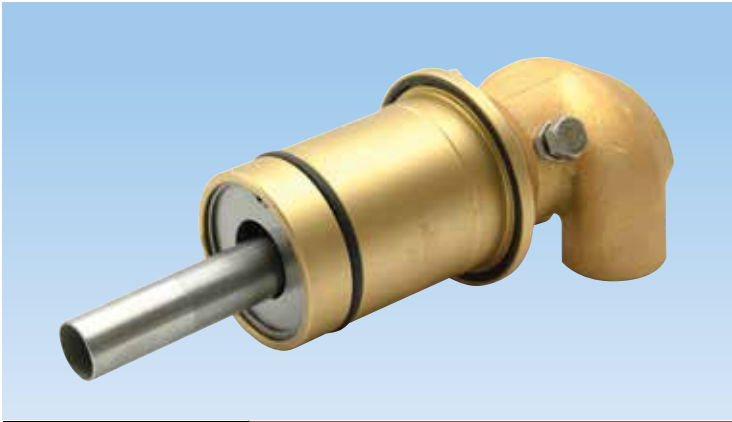

DEUBLIN 2400 Series Rotating Union

- monoflow and duoflow design
- in-the-shaft mounted
- self-supported rotating union
- flanged housing or mounted with retaining plate
- balanced mechanical seal
- seal combination:
Silicon Carbide/Silicon Carbide
- brass housing and elbow
- stainless steel rotor and supply pipe
- engineered sleeve bearing
- full-media flow
- easily field repairable

| OPERATING DATA | 2400 SERIES | |
|------------------|-------------|---------|
| Max. Pressure | 150 PSI | 10 bar |
| Max. Speed | 100 RPM | 100/min |
| Max. Temperature | 250°F | 120°C |

Monoflow Rotating Union

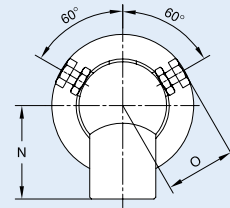
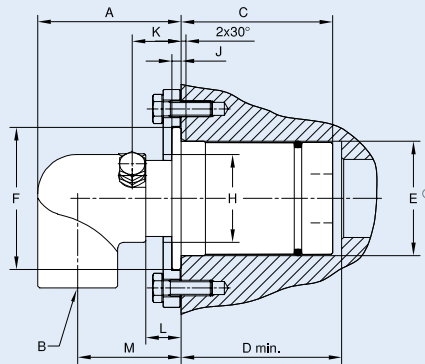

Duoflow Rotating Union

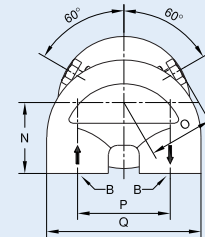
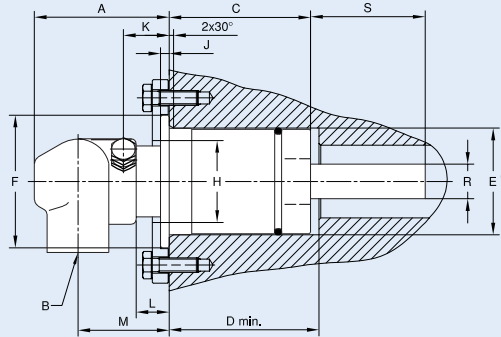

| | B Port | Ordering Number | A | C | D* | E Ø* | F Ø | H Ø | J | K | L | M | N | O | P | Q | R Ø | S | Shpg. Wt. |
|-----------|------------------|------------------|-----------------------------------|----------------------------------|-----------------------------------|----------------|----------------------------------|-----------------------------------|-------|----------------------------------|------|----------------------------------|-----------------------------------|-----------------------------------|---------------------------------|-----------------------------------|----------------|-----------------------------------|---------------------------------|
| Monoflow | 3/4" NPT | 2420-001-125 | 2 ²¹ / ₆₄ " | 2 ³ / ₈ " | 2 ⁷ / ₁₆ " | 1.825 1.815 | 2 ⁵ / ₁₆ " | 1 ¹⁵ / ₁₆ " | 3/16" | 1 ¹ / ₃₂ " | 3/4" | 1 ² / ₃₂ " | 1 ¹³ / ₁₆ " | 1 ⁷ / ₁₆ " | - | - | - | - | 1 ¹ / ₂ # |
| | G3/4" (BSP) | 2420-001-139 | 59 | 60 | 62 | 46.35 46.10 | 59 | 49 | 5 | 26 | 19 | 42 | 46 | 36 | - | - | - | - | .7 Kg |
| | 1" NPT | 2425-001-281 | 2 ¹⁵ / ₁₆ " | 3 ¹ / ₁₆ " | 3 ³ / ₄ " | 2.323 2.313 | 2 ⁷ / ₈ " | 1 ¹ / ₁₆ " | 3/16" | 1 ¹ / ₃₂ " | 3/4" | 2 ¹ / ₈ " | 1 ¹³ / ₁₆ " | 1 ¹ / ₁₆ " | - | - | - | - | 3 ¹ / ₂ # |
| | G1" (BSP) | 2425-001-172 | 75 | 78 | 83 | 59.00 58.75 | 73 | 36 | 5 | 26 | 19 | 54 | 46 | 39 | - | - | - | - | 1.6 Kg |
| Duoflow | 3/4" NPT | 2420-001-135-180 | 2 ¹⁵ / ₁₆ " | 2 ³ / ₈ " | 2 ⁷ / ₁₆ " | 1.825 1.815 | 2 ⁵ / ₁₆ " | 1 ¹⁵ / ₁₆ " | 3/16" | 1 ¹ / ₃₂ " | 3/4" | 2" | 1 ¹⁷ / ₃₂ " | 1 ⁷ / ₁₆ " | 2" | 3 ¹¹ / ₃₂ " | .511 .510 | 1 ¹⁵ / ₁₆ " | 2# |
| | G3/4" (BSP) | 2420-001-141-180 | 75 | 60 | 62 | 46.35 46.10 | 59 | 49 | 5 | 26 | 19 | 51 | 39 | 36 | 51 | 85 | 13.00 12.95 | 49 | .9 Kg |
| | 3/4" NPT | 2425-001-283-180 | 2 ¹⁵ / ₁₆ " | 3 ¹ / ₁₆ " | 3 ³ / ₄ " | 2.323 2.313 | 2 ⁷ / ₈ " | 1 ¹ / ₁₆ " | 3/16" | 1 ¹ / ₃₂ " | 3/4" | 2" | 1 ¹⁷ / ₃₂ " | 1 ¹ / ₁₆ " | 2" | 3 ¹¹ / ₃₂ " | .748 .746 | 2 ¹ / ₂ " | 4# |
| | G3/4" (BSP) | 2425-001-177-180 | 75 | 78 | 83 | 59.00 58.75 | 73 | 36 | 5 | 26 | 19 | 51 | 39 | 39 | 51 | 85 | 19.00 18.94 | 63.5 | 1.8 Kg |
| | 1" NPT | 2440-001-301-254 | 3 ⁷ / ₈ " | 3 ³ / ₁₆ " | 3 ¹¹ / ₁₆ " | 2.805 2.795 | 3 ³ / ₈ " | 2" | 3/16" | 1 ¹ / ₃₂ " | 3/4" | 2 ¹ / ₁₆ " | 1 ¹ / ₁₆ " | 1 ¹³ / ₁₆ " | 2 ¹ / ₂ " | 4 ⁷ / ₈ " | 1.130 1.125 | 1 ⁷ / ₈ " | 9# |
| G1" (BSP) | 2440-001-306-254 | 98 | 87 | 94 | 71.25 71.00 | 86 | 51 | 5 | 26 | 19 | 68 | 43 | 46 | 64 | 105 | 28.70 28.58 | 48 | 4 Kg | |

*Denotes Shaft Dimension

BEARINGLESS UNIONS FOR **CONTINUOUS CASTING**

Deublin Bearingless Technology

Conventional unions are dependent on bearings for support and smooth low torque rotation. However, bearings inherently have limitations, one of which is premature failure as a result of side loading from piping connections. Deublin has adapted this bearingless technology to CCM applications with proven in-the-field success. Call our Engineering Department for complete details and specifications.



DEUBLIN Bearingless CCM Union

- monoflow and duoflow design
- in-the-shaft mounted
- flanged housing or mounted with retaining plate
- balanced mechanical seal
- seal combination:
Silicon Carbide/Silicon Carbide
- brass housing and elbow
- stainless steel rotor and supply pipe
- full-media flow
- easily field repairable
- no internal bearing

| OPERATING DATA | BEARINGLESS CCM UNION | |
|------------------|-----------------------|---------|
| Max. Pressure | 150 PSI | 10 bar |
| Max. Speed | 100 RPM | 100/min |
| Max. Temperature | 250°F | 120°C |

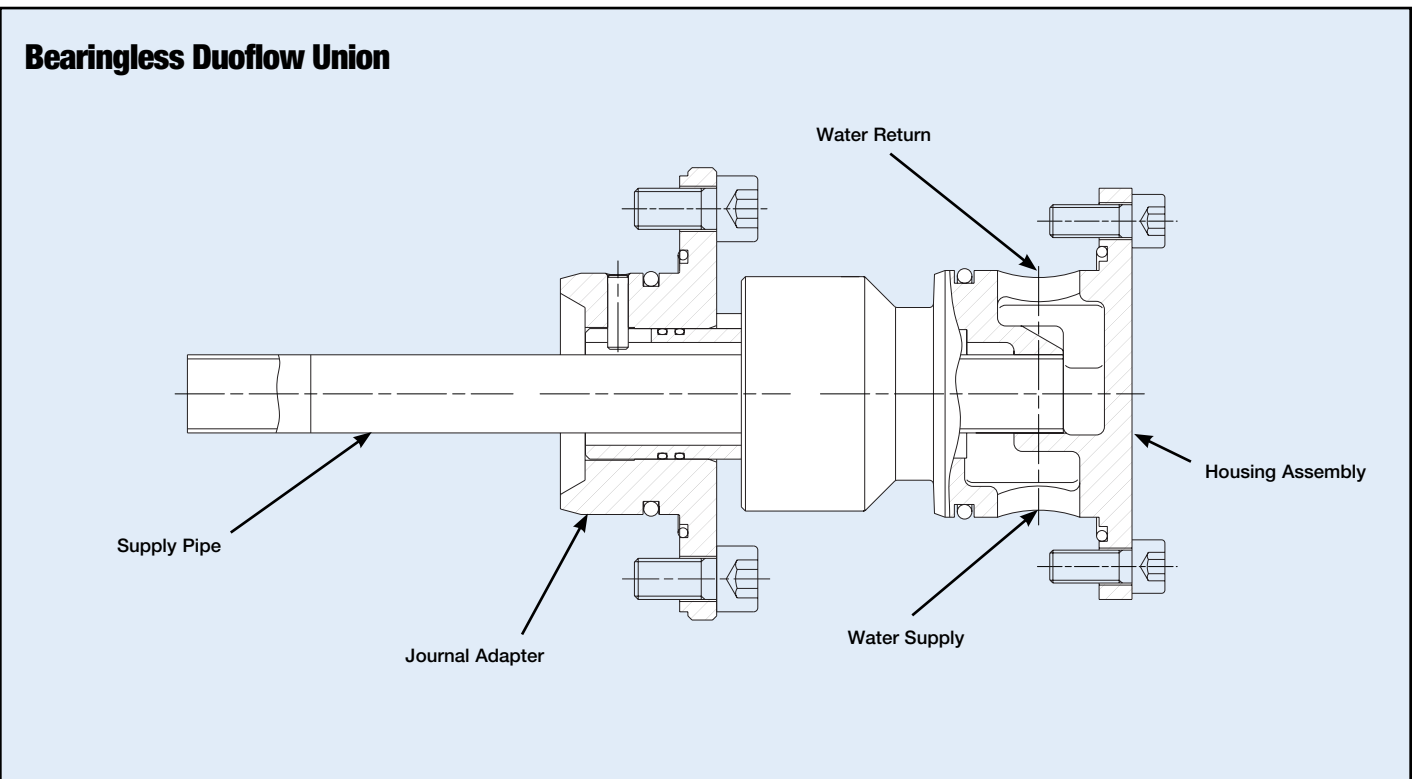

ROTATING UNIONS FOR CONTINUOUS CASTING



DEUBLIN 5000 Series Rotating Union

- monoflow and duoflow design
- externally mounted
- self-supported rotating union
- radial housing connection
- balanced mechanical seal
- seal combination - standard:
Carbon Graphite/Silicon Carbide
- keyed rotor seal
- cast iron body/brass end-cap
- stainless steel rotor ($3/4$ " - $1\frac{1}{2}$ "
- engineered sleeve bearing
- easily field repairable
- special options:
threaded vent holes

| OPERATING DATA | 5000 SERIES | |
|------------------|-------------|---------|
| Max. Pressure | 150 PSI | 10 bar |
| Max. Speed | 100 RPM | 100/min |
| Max. Temperature | 250°F | 120°C |

Duoflow Rotating Union

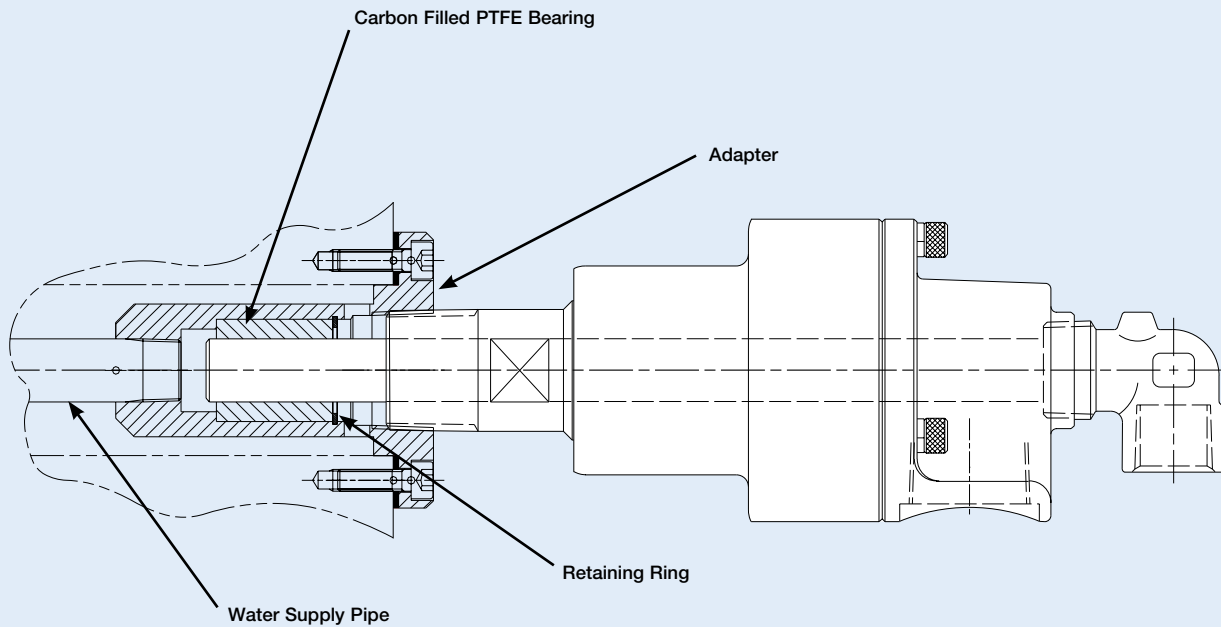

Adapter for Outboard Mounted Unions

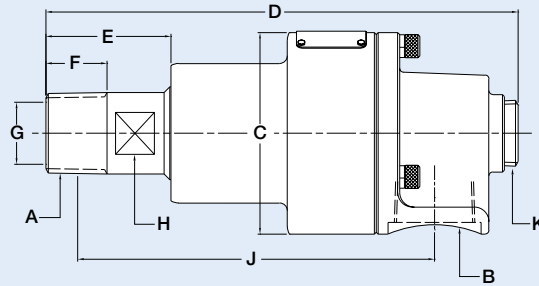

Monoflow

| | B Port | Ordering Number | A Rotor Thread* | CØ | D | E | F | G Rotor Hole | H | J | K NPT | M | O NPT | P | Q Turn Ø | R | S | Shpg. Wt. | |
|----------|------------|-----------------|-------------------|--------|--------|---------|---------|--------------|--------|---------|--------|---|-------|---|----------|---|---|-----------|-----|
| Monoflow | 3/4" NPT | 5075-001-101 | 3/4" (NPT) RH | 2 5/8" | 5 7/8" | 1 1/2" | 7/8" | 1 1/16" | 1 1/4" | 4 1/2" | - | - | - | - | - | - | - | 3 1/2# | |
| | | 5075-001-102 | 3/4" (NPT) LH | | | | | | | | | | | | | | | | |
| | | 5075-001-117 | G 3/4" (BSP) RH | 67 | 150 | 38 | 19 | 17 | 32 | 105 | - | - | - | - | - | - | - | 1,6 Kg | |
| | | 5075-001-118 | G 3/4" (BSP) LH | | | | | | | | | | | | | | | | |
| | 1" NPT | 5100-060-160 | 1" (NPT) RH | 3 3/4" | 7 7/8" | 1 3/4" | 3/4" | 1" | 1 1/8" | 5 1/2" | 3/4" | - | - | - | - | - | - | - | 6# |
| | | 5100-060-161 | 1" (NPT) LH | | | | | | | | | | | | | | | | |
| | | 5100-060-171 | G 1" (BSP) RH | 82 | 187 | 44 | 21,5 | 25,4 | 28 | 128 | 3/4" | - | - | - | - | - | - | 2,8 Kg | |
| | | 5100-060-172 | G 1" (BSP) LH | | | | | | | | | | | | | | | | |
| | 1 1/2" NPT | 5150-001-117 | 1 1/2" (NPT) RH | 4 1/4" | 9 9/8" | 2 7/16" | 1 1/16" | 1 1/2" | 1 3/4" | 7 7/16" | 1 1/4" | - | - | - | - | - | - | - | 12# |
| | | 5150-001-118 | 1 1/2" (NPT) LH | | | | | | | | | | | | | | | | |
| | | 5150-001-156 | G 1 1/2" (BSP) RH | 108 | 238 | 62 | 29 | 38 | 44 | 174 | 1 1/4" | - | - | - | - | - | - | 5,6 Kg | |
| | | 5150-001-157 | G 1 1/2" (BSP) LH | | | | | | | | | | | | | | | | |

*Female Thread also available

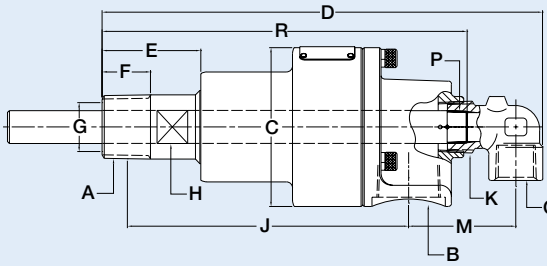

Duoflow-Fixed Supply Pipe

| | B Port | Ordering Number | A Rotor Thread* | CØ | D | E | F | G Rotor Hole | H | J | K NPT | M | O NPT | P | Q Turn Ø | R | S | Shpg. Wt. |
|---------------------------|------------|-------------------|-----------------|--------|-----------|---------|---------|--------------|--------|---------|--------|----------|--------------|--------------|----------|----------|--------|-----------|
| Duoflow-Fixed Supply Pipe | 1" NPT | 5100-060-160-083 | 1" (NPT) RH | 3 3/4" | 8 7/8" | 1 3/4" | 3/4" | 1" | 1 1/8" | 5 1/2" | 3/4" | 2 5/16" | 1/2" | 3/8" N.P.T. | - | 7 7/8" | - | 6# |
| | | 5100-060-161-083 | 1" (NPT) LH | | | | | | | | | | | | | | | |
| | | 5100-060-171-255 | G 1" (BSP) RH | 82 | 225 | 44 | 21,5 | 25,4 | 28 | 128 | 3/4" | 55 | 1/2" | G 3/8" (BSP) | - | 183 | - | 2,8 Kg |
| | | 5100-060-172-255 | G 1" (BSP) LH | | | | | | | | | | | | | | | |
| | 1 1/2" NPT | 5150-001-117-013 | 1 1/2" (NPT) RH | 4 1/4" | 11 11/16" | 2 7/16" | 1 1/16" | 1 1/2" | 1 3/4" | 7 7/16" | 1 1/4" | 2 15/16" | 3/4" | 3/4" N.P.T. | - | 9 13/16" | - | 12# |
| | | 5150-001-118-013 | 1 1/2" (NPT) LH | | | | | | | | | | | | | | | |
| 5150-001-156-221 | | G 1 1/2" (BSP) RH | 108 | 287 | 62 | 29 | 38 | 44 | 174 | 1 1/4" | 75 | 3/4" | G 3/4" (BSP) | - | 241 | - | 5,6 Kg | |
| 5150-001-157-221 | | G 1 1/2" (BSP) LH | | | | | | | | | | | | | | | | |

*Female Thread also available

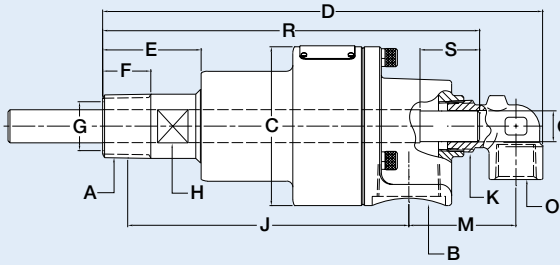

Duoflow-Rotating Supply Pipe

| | B Port | Ordering Number | A Rotor Thread* | CØ | D | E | F | G Rotor Hole | H | J | K NPT | M | O NPT | P | Q Turn Ø | R | S | Shpg. Wt. |
|------------------------------|------------|------------------|-------------------|--------|-----------|---------|---------|--------------|--------|---------|--------|----------|-------|---|----------------|----------|--------|-----------|
| Duoflow-Rotating Supply Pipe | 1" NPT | 5100-060-160-163 | 1" (NPT) RH | 3 3/4" | 8 7/8" | 1 3/4" | 3/4" | 1" | 1 1/8" | 5 1/2" | 3/4" | 2 5/16" | 1/2" | - | .621" / .619" | 7 7/8" | 1 1/4" | 6# |
| | | 5100-060-161-163 | 1" (NPT) LH | | | | | | | | | | | | | | | |
| | | 5100-060-171-347 | G 1" (BSP) RH | 82 | 225 | 44 | 21,5 | 25,4 | 28 | 128 | 3/4" | 55 | 1/2" | - | 15,95 / 15,90 | 196 | 31 | 2,8 Kg |
| | | 5100-060-172-347 | G 1" (BSP) LH | | | | | | | | | | | | | | | |
| | 1 1/2" NPT | 5150-001-117-144 | 1 1/2" (NPT) RH | 4 1/4" | 11 11/16" | 2 7/16" | 1 1/16" | 1 1/2" | 1 3/4" | 7 7/16" | 1 1/4" | 2 15/16" | 3/4" | - | 1.000" / .998" | 9 15/16" | 1 3/4" | 12# |
| | | 5150-001-118-144 | 1 1/2" (NPT) LH | | | | | | | | | | | | | | | |
| | | 5150-001-156-468 | G 1 1/2" (BSP) RH | 108 | 287 | 62 | 29 | 38 | 44 | 174 | 1 1/4" | 75 | 3/4" | - | 25,91 / 25,81 | 263 | 44 | 5,6 Kg |
| | | 5150-001-157-468 | G 1 1/2" (BSP) LH | | | | | | | | | | | | | | | |

*Female Thread also available

ROTATING UNIONS FOR STEEL COIL WINDING

Typical Examples

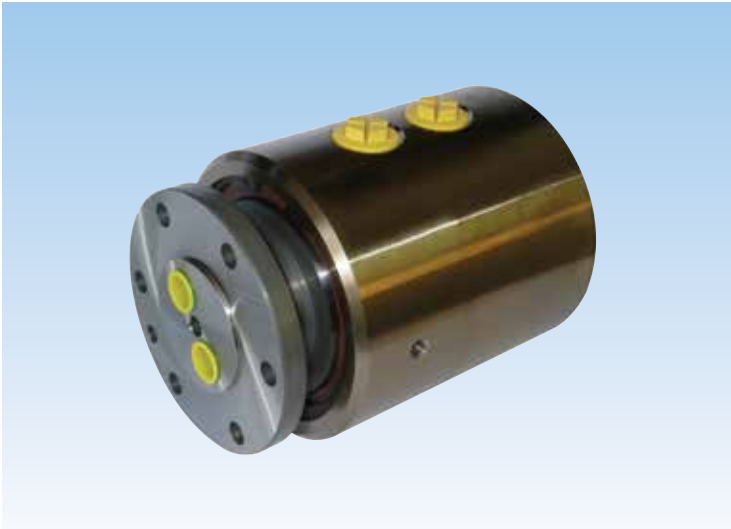

2-Passage Rotating Union with Hydrostatic Seal

- for clamping-unclamping applications at steel-strip winders

| OPERATING DATA | 7100-535 | |
|------------------|-----------|---------|
| Max. Pressure | 5,075 PSI | 350 bar |
| Max. Speed | 100 RPM | 100/min |
| Max. Temperature | 205°F | 95°C |

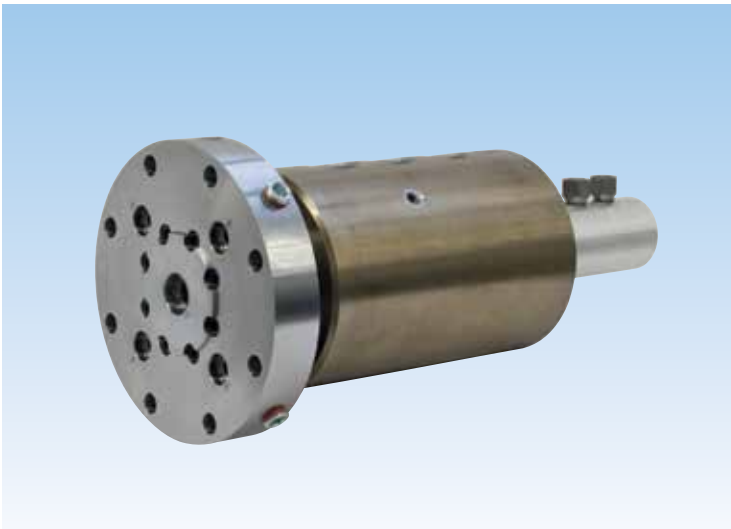

3-Passage Rotating Union with Hydrostatic Seal

- for spraying-clamping-unclamping applications at steel-strip winders

In combination with SP0077 (2-Passage)

- grease is supplied to the winding mandrel to lubricate the moving elements of the winder

| OPERATING DATA | 7100-1010 | | SP0077 | |
|------------------|-----------|---------|-----------|---------|
| Media | Hydraulic | | Grease | |
| Max. Pressure | 1,450 PSI | 100 bar | 5,800 PSI | 400 bar |
| Max. Speed | 450 RPM | 450/min | 600 RPM | 600/min |
| Max. Temperature | 160 °F | 70 °C | 160 °F | 70 °C |

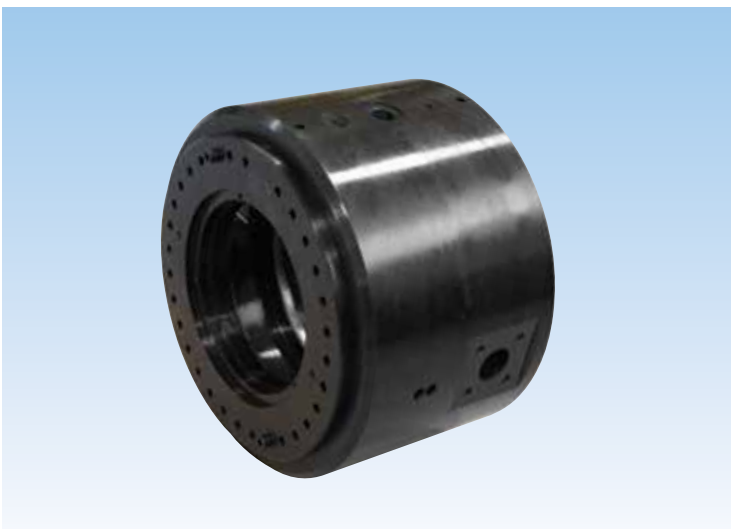

2-Passage Rotating Union with Mechanical Seal – for Around-the-Shaft Application

- for clamping-unclamping applications at steel-strip winders

In combination with SP0077 (2-Passage)

- grease is supplied to the winding mandrel to lubricate the moving elements of the winder

| OPERATING DATA | SP0283 | | SP0077 | |
|------------------|-----------|---------|-----------|---------|
| Media | Hydraulic | | Grease | |
| Max. Pressure | 2,610 PSI | 180 bar | 5,800 PSI | 400 bar |
| Max. Speed | 800 RPM | 800/min | 600 RPM | 600/min |
| Max. Temperature | 160 °F | 70 °C | 160 °F | 70 °C |

Other Models Available

UNIONS FOR LADLE TURRETS



Ladle Turret Union

- Ladle turrets require complex, heavy-duty multi-passage unions that support the hydraulic lifting of the ladle for each pour of molten metal. Deublin Ladle Turret Unions accommodate multiple media including hydraulic oil, argon, air and water.
- Typical number of ports: up to 26.

| OPERATING DATA | LADLE TURRET | | | | | | | |
|------------------|---------------|---------|---------|--------|---------|--------|---------|--------|
| | Hydraulic Oil | | Argon | | Air | | Water | |
| Max. Pressure | 3,625 PSI | 250 bar | 150 PSI | 10 bar | 150 PSI | 10 bar | 300 PSI | 20 bar |
| Max. Speed | 20 RPM | 20/min | 20 RPM | 20/min | 20 RPM | 20/min | 20 RPM | 20/min |
| Max. Temperature | 250°F | 120°C | 250°F | 120°C | 250°F | 120°C | 250°F | 120°C |

PLANE & SELF-ALIGNING SWIVEL JOINTS



Plane Swivel Joints

- Handles 360° single & multi-plane swivel movement with positive sealing
- Available in 1" through 6" sizes in threaded, welded or flanged styles
- Available in three seal materials that are compatible with many gasses, fluid & chemicals
- Spring energized seals offer leak-tight sealing at all pressures, including vacuum
- Seal can be replaced without removing bearings



Self-Aligning Swivel Joints

- Handles 360° rotary and 10° angular alignment motion with positive sealing
- Conveys hot and cold water, alternating steam and water and heat transfer fluids
- Eliminate the hazards of leaking pipe connections or catastrophic hose failures
- Outperforms and outlasts flexible hose with lower pressure drops

INSTALLATION INSTRUCTIONS

PROPER MOUNTING ENSURES LONGER UNION LIFE

Flexible hose must be used to connect the rotating union to its supply and return lines. Flexible hose ensures less side load and wear on the bearing surfaces of the union. Rigid piping should not be used. The hose should connect directly to the union, if possible, by way of a live swivel that will eliminate any torsional stress from the pressurized hose. The table shows minimum recommended lengths for the different hose diameters to provide flexible installation.

| HOSE DIAMETER | HOSE LENGTH | |
|---------------|-------------|-----|
| | INCHES | mm |
| 1/2" | 12 | 305 |
| 3/4" | 14 | 355 |
| 1" | 16 | 405 |
| 1 1/4" | 18 | 460 |
| 1 1/2" | 20 | 510 |

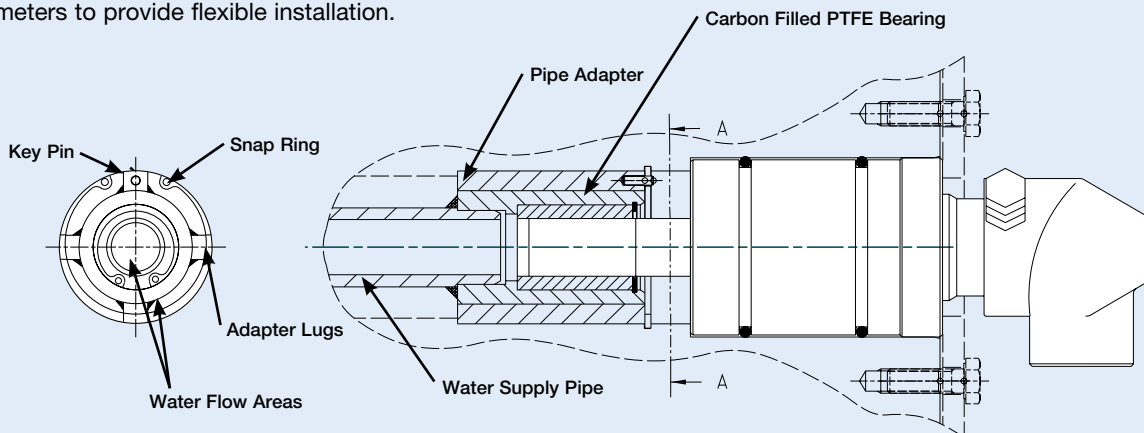

Adapter for "In-The-Shaft" Mounted Unions

Flexible Hose Installation Instructions for Deublin Rotating Unions*

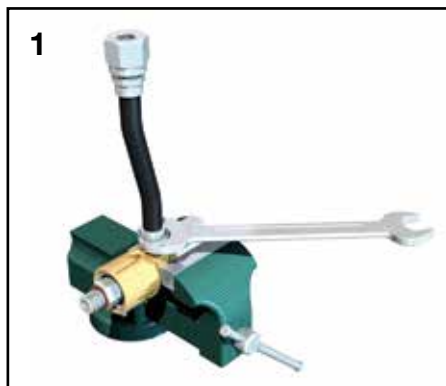

1 Mount housing in a bench vise and install hose.

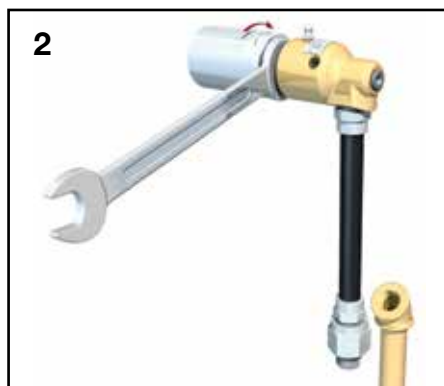

1 Install rotating union into machine.

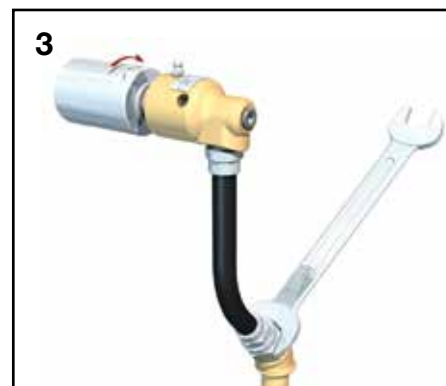

1 Connect flexible hose to supply line.

*Consult Deublin website for installation instructions for Bearingless 2400 Unions.

WARNING

DEUBLIN unions should not be used to convey flammable media (flash point $\leq 140^{\circ}\text{F}$ or 60°C) as leakage may result in explosions or fires. DEUBLIN unions should be used in accordance with standard safety guidelines for the media, and in a well-ventilated area. The use of our product on hazardous or corrosive media is strictly forbidden.

Deublin Rotating Unions General Catalog

From the world leader in rotating unions, the Deublin general engineering catalog provides application information and specifications for over 500 standard unions and 3000 models used with a broad range of materials, viscosities, temperatures, pressures and speeds. Deublin unions accommodate water, steam, hot oil, coolant and air for thousands of manufacturing, equipment and process applications. Custom unions are also available to address specific requirements.



Deublin Rotating Unions for Machine Tool

Whether CNC machining centers or automotive transfer lines, Deublin offers the broadest range of rotating union solutions for continuous through-the-spindle coolant applications. State-of-the-art features include silicon carbide seals, and dry running capability with or without pressure.



Deublin Steam Joints and Siphon Systems for the Paper Industry

Deublin has a complete line of steam inducing and condensate removal products designed specifically for the paper industry. These products are contained in a dedicated catalog. This line features the revolutionary FS Series Steam Joint with the Deltasint Stationary Siphon System designed and proven for today's high-speed paper machine's dryer sections.



Deublin Wind Energy Brochure

Deublin manufactures a complete line of high pressure hydraulic unions for wind energy applications. Available in configurations ranging from monoflow to four passage designs, with central passages for cable connection to electrical slip rings. Durability features such as water resistant construction and hardened stainless steel rotors provide unparalleled lifecycle reliability over millions of cycles.



Deublin Slip Ring Brochure

Deublin is a leader in the manufacturing of electrical slip rings, and complete slip ring/rotary union combinations for use in a variety of applications including wind turbines, robotics, centrifuges, milling, plastic molding, semiconductor and more. Custom slip rings can be designed to address such challenges as RF shielding, mixed signal handling, high frequency impedance matching, reduced temperature generation, and miniaturization.





Since its establishment in 1945, Deublin has consistently adhered to a policy of producing the best product of its kind in the market. The result of this policy has been constant growth through the years. For this progress we are grateful to our many loyal customers. We cordially invite you to visit our modern manufacturing facilities in Waukegan, Illinois; Hofheim, Germany; Montevoglio, Italy; and Dalian, China.

Sincerely,

Donald L. Deubler
Chairman of the Board



Global Headquarters in Waukegan, Illinois, U.S.A.



Hofheim, Germany



Montevoglio, Italy



ASIA

美国杜博林 Deublin 旋_接(Ü授6代理

北方 系方式：

信德 科技(北京)有限公司 CNMEC Technology

地址：北京市朝 望京街 10 望京 SOHO-T1-C 座 2115 室

*Tel: 010-8428 2935 | * Fax: 010-8428 8762

*手机：139 1096 2635

* 子 件：sales@cnmec.biz

主 ：<http://www.cnmec.net>



想了解更多，联系老杨吧

扫一扫二维码加好友，方便联系