

DEUBLIN

1124 Series Bearingless AutoSense™ Rotating Union for Coolant and Compressed Air, with Dry Running

- Single passage for coolant and compressed air
- Patented AutoSense™ technology, changes automatically between closed seals and controlled leakage, depending on media
- Full-flow design has no obstructions to trap swarf or debris
- Balanced mechanical seals made from silicon carbide for long life even under difficult operating conditions
- Anodised aluminium housing, resists corrosion
- Available with threaded rotor only



Operating Data

Media	Water-based Coolant MQL (oil mist) up to 10 bar (145 psi)
Filtration	ISO 4406 Class 17/15/12, max. 60 micron
Max. Speed	see graphic/table
Max. Pressure	see graphic/table
Max. Flow	Coolant see table
Max. Temperature	71 °C 160 °F

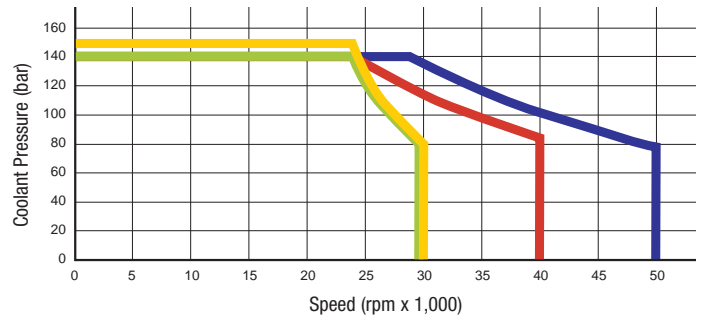

Dual Connection

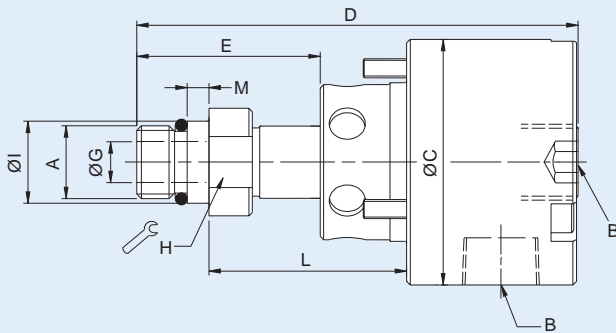

Axial Connection

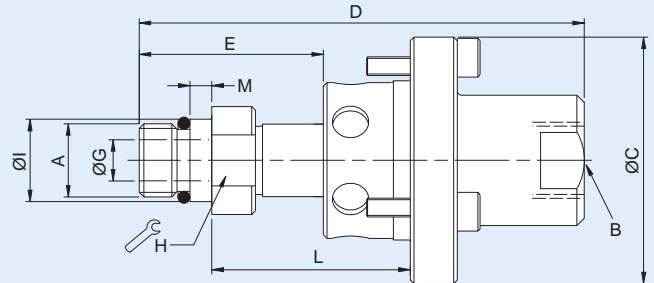

Coolant	Connection	Ordering Number	B Supply Connection	C Overall Diameter	D Overall Length	L Mounting Distance	A Rotor Connection	E Rotor Length	G Bore Diameter	H Across Flats	I Pilot Diameter	M Pilot Length	Max. Speed (rpm)
15 l/min	Radial	1124-850-847	G ¼	68	101	2	M8 x 0.5 LH	28	4	13	8.995 / 8.991	20	40,000
24,3 l/min	Axial	1124-014-015	G ¼	45	63	14	M10 x 1 LH	19	5	14	10.994 / 10.989	7	50,000
82 l/min	Radial	1124-031-590	G ¾	58	76	21.5	M16 x 1.5 LH	16	8.5	19	17.993 / 17.988	5	30,000
38 l/min	Axial	1124-036-301	PT ¾	54	97	43	M16 x 1.5 LH	16	8.5	24	17.993 / 17.988	5	30,000
24,3 l/min	Radial / Axial	1124-800-780	2 x G ¾	54	106	41.5	M16 x 1.5 LH	16	5	19	17.993 / 17.988	5	30,000